

Q-12A

Model Q-12A Loudspeaker

SOUNDSPHERE
LOUDSPEAKERS



Specifications: Q-12A

Mounting hardware included

| | |
|------------------------------------|---|
| Nominal Impedance | 8 ohms |
| Power Handling | 250W |
| Sensitivity dB @ 2.83V/1M | 97 dB |
| Sensitivity dB @ 1W/1M (2) | 97 dB |
| Frequency Response (± 3 dB) | 120 Hz - 13 kHz |
| Frequency Response (± 10 dB) | 65 Hz - 15 kHz |
| Max. Program Power | 500 W |
| Max. Continuous Power RMS | 250 W |
| Max. Power SPL @ 1 M | 121dB; 250 Watts/1 meter |
| Max. Power SPL @ 4M | 109dB |
| 70.7 Volt Transformer Taps | 250 / 121.0 |
| 100 Volt Transformer Taps (dB) | 250 / 121.0 |
| Transformer insertion loss (dB) | ≤ 1 dB |
| Low Frequency Voice Coil | 76 mm / 3" |
| Coverage Angles | Horizontal / 360 |
| Coverage Angle (-6 dB @ 2 kHz) raw | 95 |
| Enclosure - material | Fiberglass with gelcoat nish; rust-resistant hardware |
| Enclosure - description | White (paintable) and black |
| Driver - part | 12" True Coaxial |
| Inputs | Hard-wire leads |
| Height (SM = Height) | 635 mm / 25" |
| Diameter (SM = Width) | Sphere: 560 mm / Sphere: 22" |
| Weight | 17.6 kg / 39 lbs |
| Shipping Weight | 21.8 kg / 48 lbs |
| Packaging | One per box |
| Regulatory - CE | approved |
| Regulatory - RoHS | approved |

Q-12A

Model Q-12A Loudspeaker

SOUNDSPHERE
LOUDSPEAKERS

Key Features

- » Hemispherical coverage pattern
- » Accurate, full-range voice announcements
- » Enhanced high-fidelity music reproduction
- » High sensitivity (94 dB 1 W/1 m)
- » High SPL capability (118 dB @ 1 m)
- » Exclusive patent-pending Poly-Exponential Incidence Reflector
- » Hanging or surface mount
- » Standard white (paintable) and black available

Description

For high sound pressure levels in:

- Gymnasiums
- Ice Rinks
- Arenas
- Churches
- Swimming Pools
- Transportation Terminals
- Factories
- Open Public Areas
- Bars & Nightclubs
- And applications where clear voice announcements and high-fidelity foreground music are required at high sound levels.

SoundSphere's Model Q-12A omnidirectional loudspeaker provides a more powerful sound system where clear voice announcements and high-fidelity foreground music at high sound pressure levels are required. Applications include gymnasiums, ice rinks, transportation terminals, factories and nightclubs.

Along with its hemispherical coverage pattern, the Q-12A loudspeaker provides high sensitivity (97dB 1W/1m) and high SPL capability (121dB 250W/1m), and utilizes our exclusive patent-pending Poly-exponential Incidence Reflector. This loudspeaker can be mounted using our hanging kit or mounting bracket and comes in textured white.

Weather-Resistant Speakers Available for Outdoor Sound Systems

The Q-12A is also available in a weatherproof configuration (Q-12AWR) for outdoor use, featuring a protective screen over the holes and driver to prevent birds from nesting in the speaker.

Applications

Providing high-power, high-fidelity foreground music and voice, the Q-12A loudspeaker is ideal for applications such as gymnasiums, ice rinks, arenas, churches, swimming pools, transportation terminals, factories, open public areas, bars/nightclubs and anywhere that clear voice announcements and high-fidelity foreground music are required at high

sound pressure levels.

PATENTED SOUNDSPHERE TECHNOLOGIES

SoundSphere and MSE Audio Group constantly develop new technologies that enhance audio product performance. SoundSphere innovations are protected by multiple patents that explicitly cover SoundSphere's dispersion and enclosure technologies. MSE Audio Group actively defends its patents in order to protect SoundSphere resellers and end users.

Patented SoundSphere Technologies

SoundSphere and MSE Audio Group constantly develop new technologies that enhance audio product performance. SoundSphere innovations are protected by multiple U.S. and international patents, which explicitly cover SoundSphere dispersion, enclosure and dome technologies. MSE Audio Group actively defends its patents in order to protect SoundSphere resellers and end users.

Technical Data and Specification Tools

Technical Data

SoundSphere strives to provide complete and effective technical information and data to dealers, engineers and designers. All data are available from SoundTube Entertainment or at www.soundtube.com. Technical data and downloads include: EASE™ data - 3-D polar plots. EASE™ Address - 2-D modeling for distributed systems Autodesk® Revit® software Tech Sheets - Technical information and architectural specs for system engineers SoundTubeSPEC™ - Proprietary speaker placement software

Data Acquisition and Verification

All data for SoundSphere speakers are independently collected from and verified by NWAA Labs (www.nwaalabs.com) using their proprietary MACH testing system. All data are collected and analyzed according to ASTM, ISO and AES standards using EASRA, TEF and MLSSA. Full balloon data including both phase and magnitude are compiled into a variety of formats including EASE 4.x, GLL and CLF.

Architectural Specifications

The loudspeaker driver shall consist of one 12-inch (304.8 mm) treated pulp fiber woofer with a 2.8" (72 mm) titanium compression driver sharing a common magnetic circuit. Performance specifications of a typical production unit shall be as follows: Useable

frequency response shall extend from 65 Hz to 15 kHz. The vertical polar coverage shall be 155° ±6 dB. Measured sensitivity (1 Watt/1 meter) shall be at least 94 dB. The speaker shall have a rated impedance of 4 ohms. The speaker shall be available for 70- and 100-volt modes and shall include 4 power tap selection leads for use with electrical wire nuts or crimp caps. Rated power capacity shall be at least 250 Watts continuous (RMS) and conform to EIA-426-B testing. Calculated maximum continuous output at 1 meter shall be 118 dB. The complete loudspeaker shall be no more than 25 inches (635 mm) in height. The driver shall be mounted in a spherical enclosure made of fiberglass with gelcoat finish that is no more than 22 inches (260 mm) in diameter. The reflector shall be no more than 26 inches (660 mm) in diameter. The complete loudspeaker shall weigh no more than 39 lbs. (17.6 kg). Hardware shall be rust and corrosion resistant, constructed of stainless steel, plated steel or aluminum. Optional accessories shall include: a 250-Watt Line Matching Transformer (TX250) with taps for 70- and 100-Volt constant voltage systems; a Mounting Bracket (MBL) to mount flat against a ceiling surface; a three-element Hanging Kit (HKL) for single-point suspension; a Universal Beam Clamp (BCL); a Large Screen (SL) to protect the speaker from foreign objects; and a Large Screen with Weather Filter (SWFL) that additionally offers a water protection barrier. The system shall be the SoundSphere® Model Q-12A for wide-range, wide coverage sound dispersion at high sound pressure levels.

SoundSphere

8005 W 110th St., Suite 208
Overland Park, ks 66210
Phone 913.663.5600
Fax
Toll Free 855.663.5600
<https://soundsphere.mseaudio.com>
All SoundSphere products come with a 5-year limited warranty.

Q-12A

Model Q-12A Loudspeaker

SOUNDSPHERE
LOUDSPEAKERS

Graphs and Plots

Directivity Index

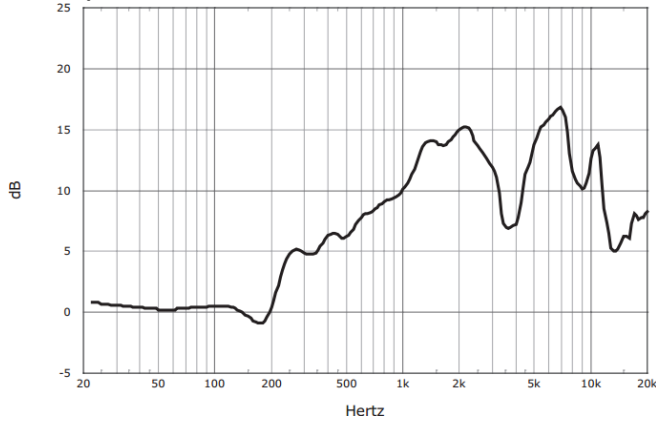

Hemispherical Frequency Response

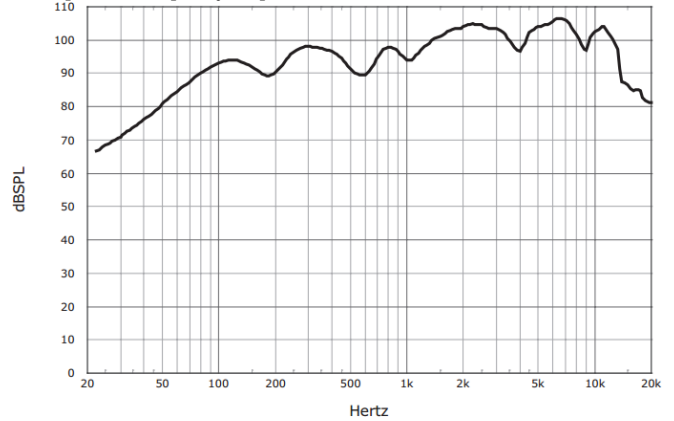

Impedance/Phase

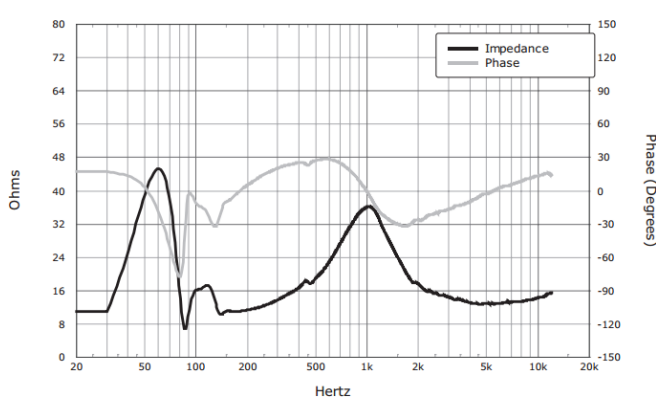

Vertical Beamwidth (+/- 6 dB)

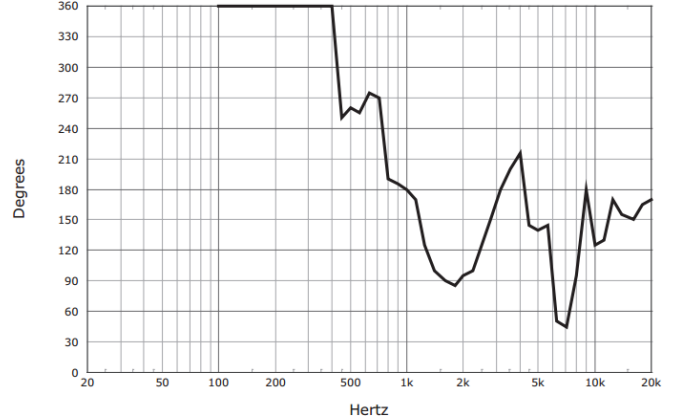

125 Hz

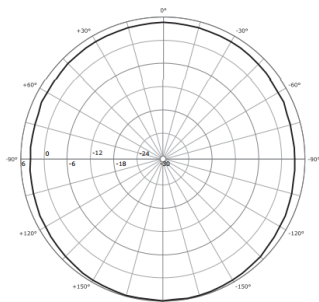

250 Hz

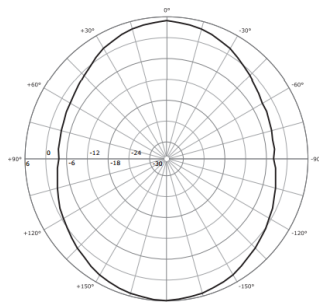

500 Hz

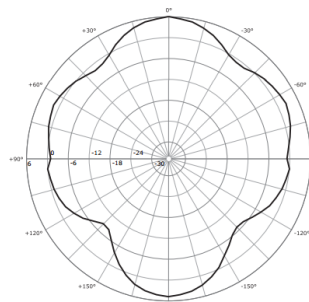

500 Hz

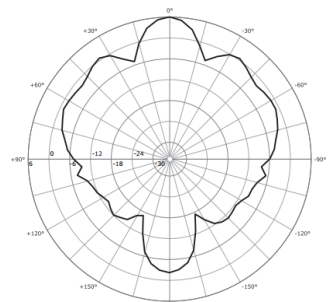

2000 Hz

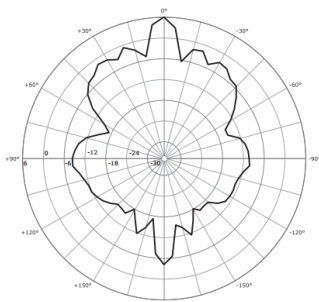

4000 Hz

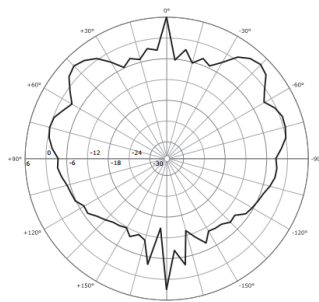

8000 Hz

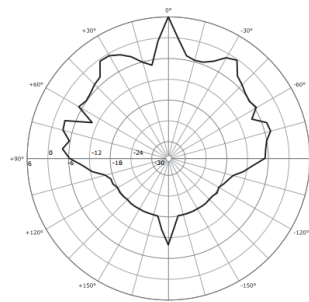

8000 Hz

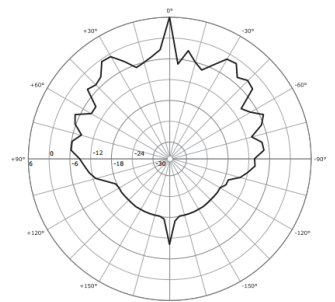

Q-12A

Model Q-12A Loudspeaker

SOUNDSPHERE
LOUDSPEAKERS

Mechanical Drawings

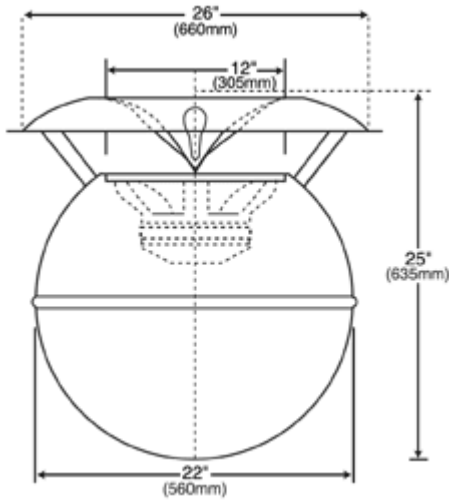

Optional Accessories

**Line Transformer
(TX250)**

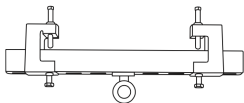

**Universal Beam Clamp
(BCL)**

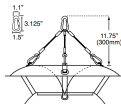

Hanging Kit (HKL)



**Driver Protection Screen
(SL)**

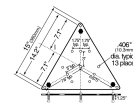

Mounting Bracket (MBL)



**Driver Protection Screen
(SWFL)**